

**FEATURES :**

- **Stopband Frequency 175 to 220MHz**
- **50dB Rejection**
- **Passband up to 1GHz**

**SPECIFICATIONS**

Stopband Frequency, [MHz]	175 to 220
Stopband Attenuation, [dB] min.	50
Lower Passband Frequency, [MHz]	DC to 150
Higher Passband Frequency, [MHz]	245 to 1000
Passband Loss, [dB] max.	1.5
Passband Return Loss, [dB], min	16
Insertion Loss @165 & 230MHz[dB], max.	15

**Operating Characteristics**

Input Power, [W] with matched load	1
Impedance, [Ohm]	50
Operating Temperature, [°C]	-20 to +60

**Ordering Information**

<b>Model No.</b>	<b>Connectors</b>
FSL10-175-220-SMA	SMA-female

**Outline drawing**                      dimensions in mm

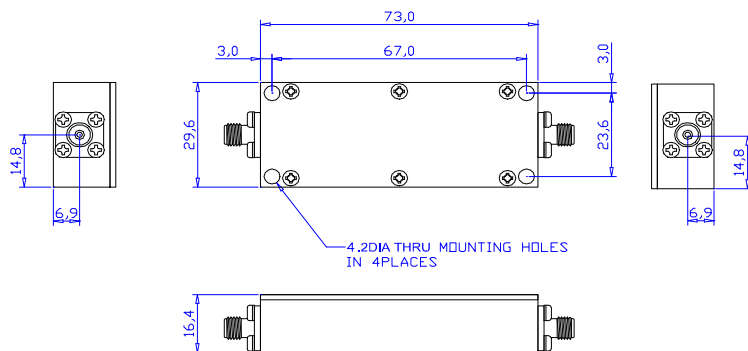

**Typical Performance\***

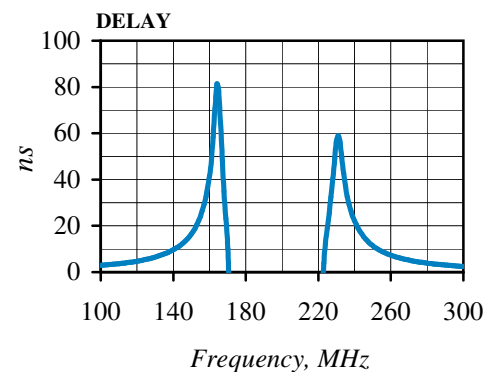
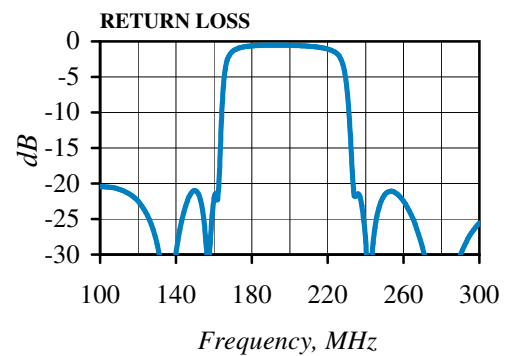
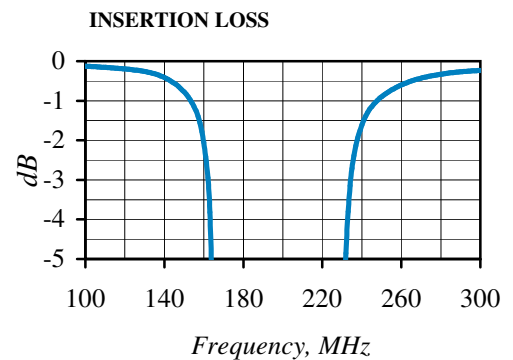
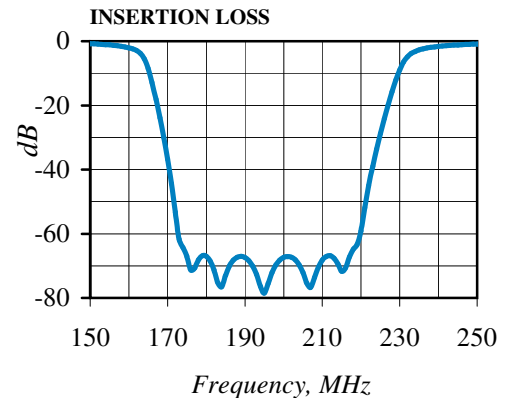

\*Simulation only, real filter may vary  
Specifications Subject To Change Without Notice

Rev. A 12.01.2023

